



Electrolux
PROFESSIONAL

**Modular Cooking Range Line
700XP Freestanding Electric
Boiling Pan 60lt indirect heat**

ITEM # _____

MODEL # _____

NAME # _____

SIS # _____

AIA # _____



371272 (E7BSEHINFO)

* NOT TRANSLATED *

Main Features

- Kettle is suitable to cook, sauté or poach all kinds of produce.
- Produce is uniformly heated in the base and side walls of the kettle by an indirect heating system that uses integrally generated saturated steam at a temperature of 110° C in the jacket.
- Pressed cooking vessel and lid in 316 AISI Stainless steel.
- Unit to feature high efficiency heating elements (9.4 kW) with energy control and temperature limiter.
- External valve allows to manually evacuate excess air accumulated in the jacket during heating phase.
- Appliance is IPX4 water resistance certified.
- Solenoid valve to refill with hot and cold water.
- Safety valve avoids overpressure of the steam in the jacket.
- No overshooting of cooking temperatures, fast reaction.
- Large capacity drain tap enables precise portioning of the discharged food, especially small quantities.
- Firmly fitting cover to reduce cooking time and save energy costs.
- Ergonomic: unique ratio vessel diameter and height; depth facilitates stirring and gentle food handling.
- Discharge tube and tap are very easy to clean from outside.
- Smooth large surfaces, easy access for cleaning.
- Pressure switch control monitors energy and water consumption.
- Exterior panels in Stainless Steel with Scotch Brite finish.
- One piece pressed 1.5 mm work top in Stainless steel.
- Model has right-angled side edges to allow flush fitting joints between units, eliminating gaps and possible dirt traps.
- Unit delivered with four 50 mm legs in stainless steel as standard (all round Stainless steel kick plates as option).

Construction

- One piece pressed 1.5 mm work top in Stainless steel.
- IPX4 water resistance certification.
- [NOT TRANSLATED]

Sustainability



- Closed heating system – no waste of energy.
- Firmly fitting cover to reduce cooking time and save energy costs.
- Pressure switch control monitors energy and water consumption.

Optional Accessories

- Junction sealing kit PNC 206086

APPROVAL: _____



Experience the Excellence
www.electroluxprofessional.com

Front

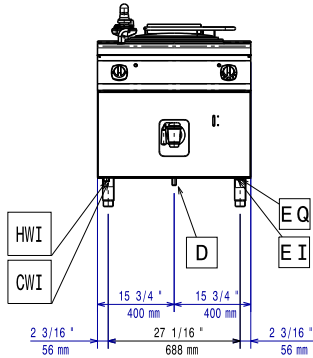

Side

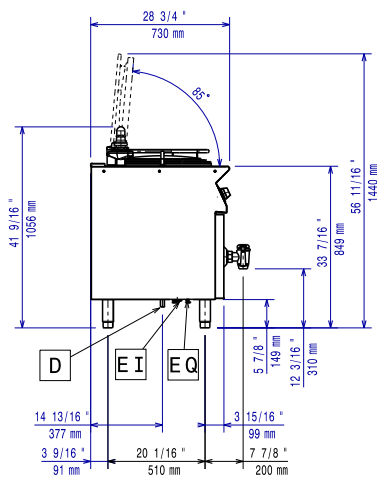

- CWI = Cold Water inlet 1 (cleaning)
- D = Drain
- EI = Electrical inlet (power)
- HWI = Hot water inlet

Top

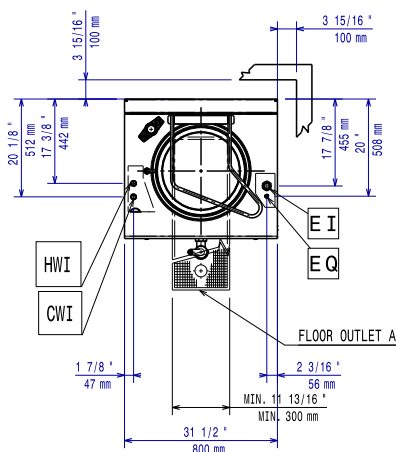

Electric

Supply voltage: 400 V/3N ph/50-60 Hz
 Total Watts: 9.4 kW
 Predisposed for:

Water:

Water drain outlet size: 1 1/2"

Key Information:

No clearance needed on rear sides of unit if wall is of non combustible type. If wall is combustible, minimum 50 mm wall clearance should be maintained.

Pan useful capacity: 60 lt
 Vessel (round) diameter: 420 mm
 Net weight: 100 kg
 Shipping weight: 88 kg
 Shipping height: 1140 mm
 Shipping width: 900 mm
 Shipping depth: 920 mm
 Shipping volume: 0.94 m³
 Certification group: EBPI76M